

# Evacuatable Pellet Dies

## Make solid pellets from powder materials

Pellet dies are used to compress powders into solid form using a hydraulic press. Our pellets are made from the highest quality materials and manufactured to high dimensional tolerances for use with vacuum pumps.

These pellet dies are particularly suited to making KBr pellets for FTIR spectroscopy and samples for XRF spectroscopy. However, almost any soft, dry powder material can be pressed using these dies.

### Key Features

- **440C stainless-steel construction** increases durability and avoids excessive expansion under load.
- **Polished inner pressing faces** ensure smooth finish on pellets – important for spectroscopy applications.
- **Vacuum port** for removing excess air from the die during the pressing process to improve pellet quality.



10 mm die

5 mm die



40 mm die

## Ordering information

Die Size (Pellet Diameter)	Maximum load	Complete Die	Base	Body	Plunger	Steel Pellets	Tungsten Pellets	O-ring	Extractor cap
5 mm	2 tonnes	GS03060	GS03050	GS03064	GS03063	GS03061	--	GS03062	GS03069
10 mm	5 tonnes	GS03100	GS03050	GS03104	GS03103	GS03101	--	GS03102	GS03025
13 mm	10 tonnes	GS03000	GS03050	GS03040	GS03030	GS03010	--	GS03020	GS03025
20 mm	25 tonnes	GS03165	GS03191	GS03169	GS03168	GS03166	--	GS03167	GS03521
32 mm	40 tonnes	GS26101	GS26141	GS26111	GS26121	GS26131	GS26133	GS26151	GS26161
40 mm	40 tonnes	GS26102	GS26141	GS26112	GS26122	GS26132	GS26134	GS26152	GS26161
32 mm (No vacuum port)	40 tonnes	GS26103	GS26141	GS26113	GS26121	GS26131	GS26133	GS26151	GS26161
40 mm (No vacuum port)	40 tonnes	GS26104	GS26141	GS26114	GS26122	GS26132	GS26134	GS26152	GS26161

## Dimensions

Die Size (Pellet Diameter)	Dimension A	Dimension B	Dimension C	Dimension D	Dimension E
5 mm	14.3 mm	38.1 mm	12.7 mm	23.0 mm	50.8 mm
10 mm	16.6 mm	18.4 mm	12.7 mm	23.0 mm	50.8 mm
13 mm	16.6 mm	18.4 mm	12.7 mm	23.0 mm	50.8 mm
20 mm	21.4 mm	35.8 mm	19.0 mm	27.8 mm	68.3 mm
32 mm	A + B + C + D = 105.0 mm				68.3 mm
40 mm	A + B + C + D = 105.0 mm				68.3 mm

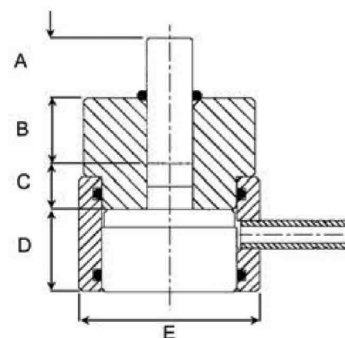

Each die consists of five main parts: a base, body, plunger, and two internal pressing pellets. In addition to these there is a rubber O-ring for vacuum sealing and a plastic or metal ring for sample extraction. Tungsten internal pressing pellets are available for the 32 mm and 40 mm dies for XRF applications involving analysis of iron.