



Produttore di ghiaccio con contenitore incorporato - Sistema granulare
Produzione giornaliera fino a 125 kg

| | |
|----------------|------------|
| Hotel | ██████████ |
| Ristoranti | ██████████ |
| Fast food | ██████████ |
| Bar | ██████████ |
| Discoteche | ██████████ |
| Mercati ittici | ██████████ |
| Supermercati | ██████████ |
| Medicale & SPA | ██████████ |
| Industrie | ██████████ |

► **Position n°**



► **Features & Plus**

- Ghiaccio granulare 80-82% dry
- 1L (acqua) = 1kg (ghiaccio) - solo A
- Carrozzeria AISI 304 Scotch Brite
- Classe Tropicale + 43° C
- Piedini acciaio inox regolabili
- Filtro Aria smontabile e pulibile
- Evaporatore in Acciaio AISI 304
- Condensazione aria o acqua
- Interno arrotondato per facile pulizia
- Isolamento contenitore HCFC-Free
- Bacinella acqua sigillata antipolvere
- RoHS Free
- Sportello isolato con apertura a scomparsa
- Funzionamento elettromeccanico
- Interruttore ON/OFF
- Caricamento automatico dell'acqua
- Voltaggio standard e voltaggi speciali
- HFC Free



Carrozzeria AISI 304 Scotch Brite



Filtro Aria smontabile e pulibile



Evaporatore in Acciaio AISI 304



Bacinella acqua sigillata antipolvere



Sportello isolato con apertura a scomparsa

► **Prod. 24h**

| T. aria | T. acqua | | Kg | Lbs | |
|---------|----------|-------|-------|-----|------|
| | 10° C | 50° F | | | 7° C |
| 21° C | 70° F | 15° C | 60° F | 113 | 249 |

Garanzia 2 Anni
soggetta a limitazioni

► **Certificazioni disponibili per questo modello**



Intertek



www.bremaice.it
info@bremaicegroup.it

We are Brema





Ice Flakes

GB 902 HC



Produttore di ghiaccio con contenitore incorporato - Sistema granulare
Produzione giornaliera fino a 125 kg

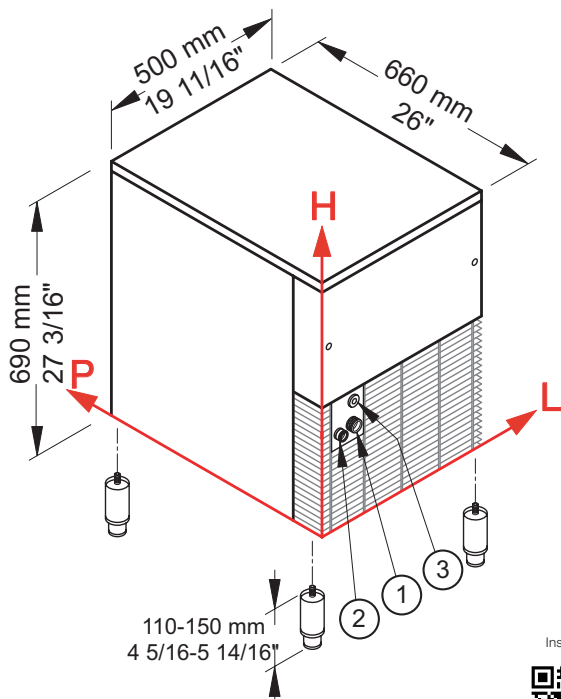

► Condizioni d'installazione

- Installazione: **Interna**

| | Min | Max |
|-------------------------|-----------------|-----------------|
| Temperatura ambiente | +10° C / +50° F | +43° C / 110° F |
| Temperatura acqua | +3° C / +37° F | +32° C / +90° F |
| Voltaggio | -10% | +10% |
| Pres. acqua in ingresso | 1bar (14 psi) | 6bar (84 psi) |

► Performance

| | Temperatura acqua | Temperatura acqua | | | | | |
|------------------|-------------------|-------------------|--------|---------|-------|---------|-------|
| | | 7° C | 45° F | 15° C | 60° F | 21° C | 70° F |
| Temperatura aria | 10° C | 125 kg | | | | | |
| | 50° F | 276 lbs | | | | | |
| | 21° C | | 113 kg | | | | |
| | 70° F | | | 249 lbs | | | |
| | 32° C | | | | 93 kg | | |
| | 90° F | | | | | 205 lbs | |

► Connessioni

Le misure sono riferite all'angolo del retro in basso a sinistra (L-H-Ø)

- ① Ingresso acqua: 99 mm / 3 14/16" - 158 mm / 6 4/16" - 3/4" ② Scarico acqua: 48 mm / 1 14/16" - 151 mm / 5 15/16" - 24 mm / 15/16"
- ③ Connessione elettrica: 87 mm / 3 7/16" - 230 mm / 9 1/16"

► Dati tecnici

| | |
|------------------------------|---------------------------------|
| Produzione in 24h | 113 kg / 249 lbs |
| Capacità contenitore, fino a | 20 kg / 44 lbs |
| Condensazione | A - W |
| Refrigerante | R290 |
| Voltaggio standard | 220-240 V ~ 50 Hz |
| Potenza media assorbita | 470 W |
| Fusibile | 10 A |
| Consumo Elettrico | 11 kWh/100kg |
| Finitura | Acciaio inox 18/8, scotch brite |

| | |
|-------------------------------|-------------------------------|
| Consumo d'acqua | A: 1 l/kg - 12,0 gal/100 lbs |
| | W: 7 l/kg - 84 gal/100 lbs |
| Dimensioni (L-P-H mm) | 500 - 660 - 690 |
| (L-P-H in) | 19 11/16 - 26 - 27 3/16 |
| Dimensioni imballo (L-P-H mm) | 550 - 720 - 880 |
| (L-P-H in) | 21 10/16 - 28 6/16 - 34 10/16 |
| Peso netto | 59 kg / 130 lbs |
| Peso lordo | 67 kg / 148 lbs |

Tutti i dati tecnici sono da considerarsi validi alle seguenti condizioni:

Dimensioni esclusi i piedini
Temperatura ambiente +21° C
Temperatura acqua +15° C
Consumo elettrico a +32° C (voltaggio standard)
Potenza media assorbita a +43° C (Voltaggio standard)

I modelli ed i dati riportati possono essere soggetti a modifiche senza alcun preavviso

Rev. 00 - Pubblicato Marzo 2021



www.bremaice.it
info@bremaicegroup.it

We are Brema

